

Battery Charger Controller - Series PBCC



Function:

Charge controllers are designed for automation of Battery Charging in Panel Boards. Many electrical control systems requires battery back-ups. To keep these batteries in healthy conditions, it is desirable that a reliable charging system should be built in. Charge controllers automatically selects mode of charge- Boost/ Trickle. It protect the charging system from over load, Reverse Battery Connection.

Application:

AMF Panel, Relay Panel,
Annunciation Panel. Five Alarm Panels.



Operating Principal:

Battery Charger Controller series PBCC regulates primary volts of Step down transformer in relation to battery volts and current. It has Constant Current(CC) Constant Volt (CV) mode auto selection. In built circuit checks the current drawn by the battery. If it exceeds the set limit, CC circuits operates resulting in reduced voltage to keep current constant, If current drawn is within the set limit, CC is off and out put voltage will be as per voltage set. This ensures quick charging of battery and no chance of over charging it.

Auto Trickle / Boost selection
Over current protection
Battery Reverse Protection

Specifications:

Mains Supply : 230 V AC +/- 10 % 50 Hz.
 Battery Volts : 12 V / 24 V.
 Charging Current : 10 / 15 A.
 Sensing : a) Battery Volt
 b) Current- built in CT
 Mode selection : Automatic
 Boost / Trickle
 Protection : a) Over Load
 b) Battery Reverse Connection
 LED Indications : a) Mains
 b) Boost
 c) Trickle
 d) Battery Reverse
 Mounting : Flash
 Terminals : Reverse terminals.
 Enclosure : ABS Molded
 Dimensions : 96 x 96 x 65 (D) mm
 Cut out : 92 x 92 mm

Selection Chart

Model No.	Nominal Battery Volt	Max. Charging Current	Recommended Transformer		Recommended Bridge
			P/S Voltage	V A Rating	
PBCC 1210	12 V	10 A	230/16 V AC	200 VA	25 A
PBCC 1215	12 V	15 A	230/16 V AC	300 VA	35 A
PBCC 2410	24 V	10 A	230/32V AC	400 VA	25 A
PBCC 2415	24 V	15 A	230/32V AC	550 VA	35 A

Block Diagram:

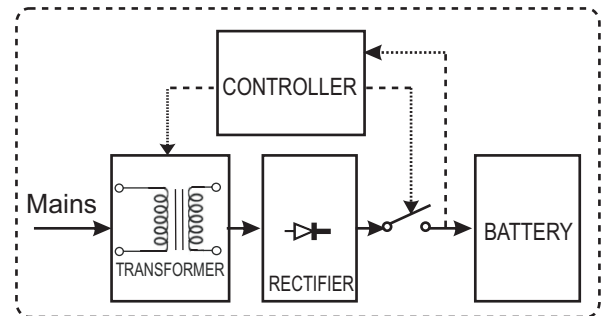

Circuit Diagram:

